

## Service Notes

### Tubes

Tubes are consumables, as they have a given usable lifespan. They are part of the heart of the tone, so keeping correctly operating tubes is essential. Tubes can fail catastrophically or gradually, and it's good to know what to look for if they start to go bad. Periodically inspect them and look to see if anything inside the tube is glowing cherry red other than the normal orange glow of the filament. This would indicate a situation where the tube is conducting more current than it is capable of handling and most likely about to fail. Two other conditions to observe are: 1) filaments not glowing or 2) a miniature fireworks display inside the tube. Any of the above conditions indicate serious problems with the tube and should be taken care of immediately. Tubes quite often are the cause of spurious noise in the amp. Microphonic tubes will squeal or rattle with the vibrations of the cabinet. If suspected, tap each tube lightly with a pencil with the amp powered up—the suspect tube will let you know. Note that there is a normal metallic clinking when doing this, but a microphonic tube will be quite loud.

Replacing preamp tubes will not require any adjustment, but the power tubes will need rebiasing to assure proper operation. After power tube replacement, initially inspect the tubes often to assure there are no “cherry red” components within the tube. Tubes today can have a wide variety of tolerances and a re-bias is highly recommended with new ones.

**NOTE! Capacitors may retain an electric charge and can be dangerous even when the unit is off, unplugged, and has not been played for an extended period of time. USE CAUTION!!!!**

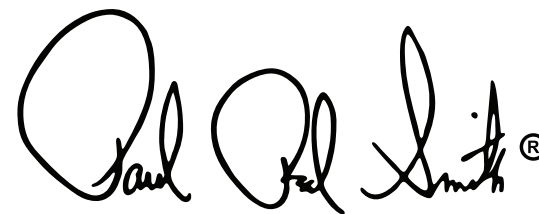
The image shows the Paul Reed Smith signature logo in a stylized, cursive font. The signature reads "Paul Reed Smith" followed by a registered trademark symbol (®).

## Archon Guitar Amplifier User's Manual

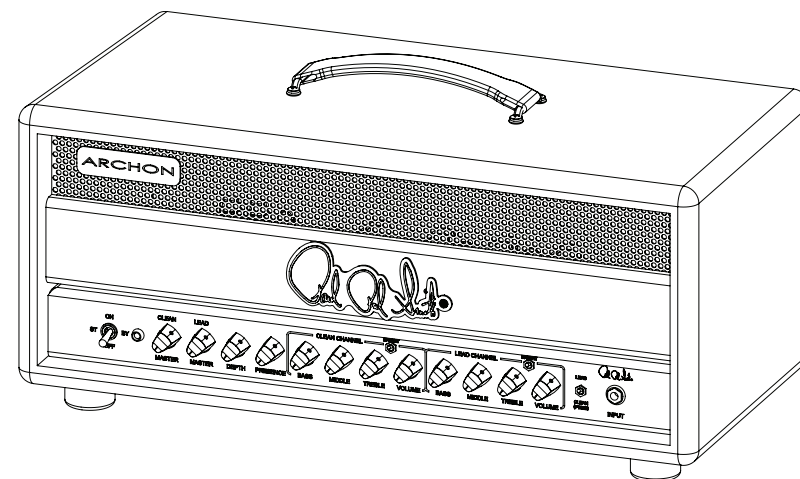

© 2014 PRS Guitars - All rights reserved.

"Paul Reed Smith," "PRS," the PRS logo, the PRS Paul Reed Smith logo, the Paul Reed Smith signature, the bird inlays, the headstock bird, the PRS headstock shape, the PRS body shape, the PRS "scoop" design, "Singlecut", "Mira" and the "SE" are all registered trademarks of Paul Reed Smith Guitars "Custom 24," "Modern Eagle," "SE Custom," "SC 245," "SC 250," "Starla", "Tonare", "Sewell", "Blue Sierra", and "Angelus" are all trademarks of Paul Reed Smith Guitars. The Birds, New Birds, are copyrighted by PRS Guitars.

LIT-AMP-MAN-ARCH-REV-B

## Using your PRS Amplifier

**IMPORTANT:** Before using your amplifier, refer to the IMPORTANT SAFETY INSTRUCTIONS insert supplied with the product.

### Powering Up:

1. Make sure your speaker cabinet is connected to the correct speaker output impedance jack with a high quality speaker cable. Do not use guitar cords.
2. Make sure the power cord is connected to the correct grounded outlet.
3. Make sure there is at least 6 inches of clearance behind the amplifier to allow for proper cooling. Never place the amplifier against a wall or other equipment, and keep it clear of other heat sources, such as other amplifiers or stoves. Make sure there are no flammable items, such as curtains, behind the amp. Do not drape items over the amps that can prevent proper cooling. Do not set drinks or other liquids on top of the amp that can spill into the amp.
4. To increase the life of the tubes, set the "Standby" switch to the STANDBY position before powering on. Turn the POWER switch on and let the amplifier warm up for 2 minutes before setting the standby switch to "ON". If this is the first time you are turning on the amp, check to see if all of the tubes are glowing.
5. Plug in the guitar cable, turn the volume knob down, and turn the standby switch on and wait a few seconds for the bias to settle. Bring the volume up and play some tunes.

This equipment is capable of very high sound pressure levels. Prolonged exposure may cause hearing damage.

This equipment contains no user-serviceable parts. Refer all repairs to qualified service personnel.

Ensure that the mains plug is easily accessible to allow the unit to be switched off.

Only connect this unit to an earthed supply socket.

THIS UNIT IS CLASS I CONSTRUCTION AND MUST BE EARTHED!

## Archon Amplifier Front Panel Controls

**Input:** ¼" Standard Mono Guitar Cable.

**Lead/Clean Selector:** Select your channels when not using your footswitch. When footswitch operation is desired, select the clean channel for proper operation.

**Channel Controls:** Each channel is equipped with a Volume, Treble, Middle, Bass, and Master control. Use the Volume control to adjust the level of preamp gain. Use the Master control to adjust the overall channel volume. Adjust the tone controls to taste.

**Bright Switches:** These switches allow you to set the overall brightness of each channel.

**Presence/Depth Controls:** The Presence and Depth controls are global and affect both channels. Presence affects the upper high-end, and Depth affects the ultra-low frequencies.

**On/Standby/Off:** When this switch is in STANDBY, the amplifier tubes are effectively turned off, but are still being warmed by the filaments. Keep this switch set to STANDBY when powering on the amplifier for at least 2 minutes to allow the tubes to warm up. This also helps extend the life of the tubes. When set to ON, the tubes are turned on and the amplifier can be used.

**LED Indicator:** Regularly check that when power is applied the mains indicator lights. If the indicator fails, return the unit for servicing. It must not be used with a faulty indicator.

## Rear Panel Controls

**Mains Socket:** Always use the mains lead supplied. Your sales outlet can provide a lead suitable for your country. Always disconnect the equipment from the mains and ancillary units before moving.

**Fuses:** This amplifier is equipped with multiple accessible fuses. Replacement fuses must be of the same type and rating as indicated. Failure to comply may result in permanent damage to the product, and/or create a safety hazard. Always disconnect the equipment from the mains supply before replacing a fuse.

**Mains Fuses:** These are located in the mains socket.

**Filament Fuses/B+ Fuse:** These are located on the top rear of the chassis and are accessible via thumb-turn fuse holders.

**Safety Symbols:** The following symbols mean:



Warning: read instructions to understand possible hazard



Danger: electrical shock hazard

**Effects Loop:** This amplifier features a bypass-able series effects loop that is integral to the overall sound of the amp. Connect the Send jack with a ¼" mono instrument cable to the input of your pedal(s). Connect your pedal(s) output to the Return jack also using a ¼" mono instrument cable.

**Output Power (100 Watt):** This control allows you to switch off two of the four power tubes. This causes a volume decrease as well as gives you tonal variation. For ideal operation, switch the impedance setting to ½ the normal value when using the 50W setting. For example, when using the 100W setting going into an 8 Ohm cabinet, use the 8 Ohm impedance setting. When using the 50W setting, switch the impedance selector to 4 Ohms.

**Output Power (50 Watt / 25 Watt):** This control allows you to switch between pentode and triode power tube operation. This causes a volume decrease as well as gives you a tone and "feel" variation. Unlike other half power switches, there is no need to change the speaker impedance with this model.

**Bias Jacks:** These jacks measure the power tube current draw in mV. ImV = ImA. Review the information on the back of this manual for guidance on replacing tubes. Biasing and tube replacement should be performed only by a qualified technician.

**Speaker Jacks:** This is the main output for your speaker cabinet(s). Jacks are wired in parallel. Only use a high quality speaker cable. Never use an instrument cable. Please see "Impedance Selector" section below.

**Impedance Selector:** Use this switch to match the amp to the impedance of your speaker cabinet(s). The total speaker impedance must be determined before connecting to the amp. It is not recommended to exceed 2 total speaker cabinets. Be sure to only use cabinets with the same impedance rating. Failure to do so can damage the amp. The combined value of 2 matching cabinet impedances is half of the value of one cabinet's impedance. Examples: Two 8 ohm cabinets combine to create a 4 ohm combined impedance. If using two 16 ohm cabinets, set the Impedance Selector to 8.

**Note:** Confirm the total impedance of your choice cabinets and adjust your Impedance Selector accordingly. Failure to do so can cause arcs on the tube sockets, failure of power tubes, or even failure of the amp.

**Footswitch Jack:** Connect the included footswitch to control channel switching and the effects loop bypass function. When using the footswitch, select the clean channel on the amplifier front panel for proper function. Only use the included footswitch. Connection of an improper footswitch may result in damage to the amplifier.